

2021



# ***Log Max 6000V***



**HEADS ABOVE THE COMPETITION**

[logmax.com](http://logmax.com)



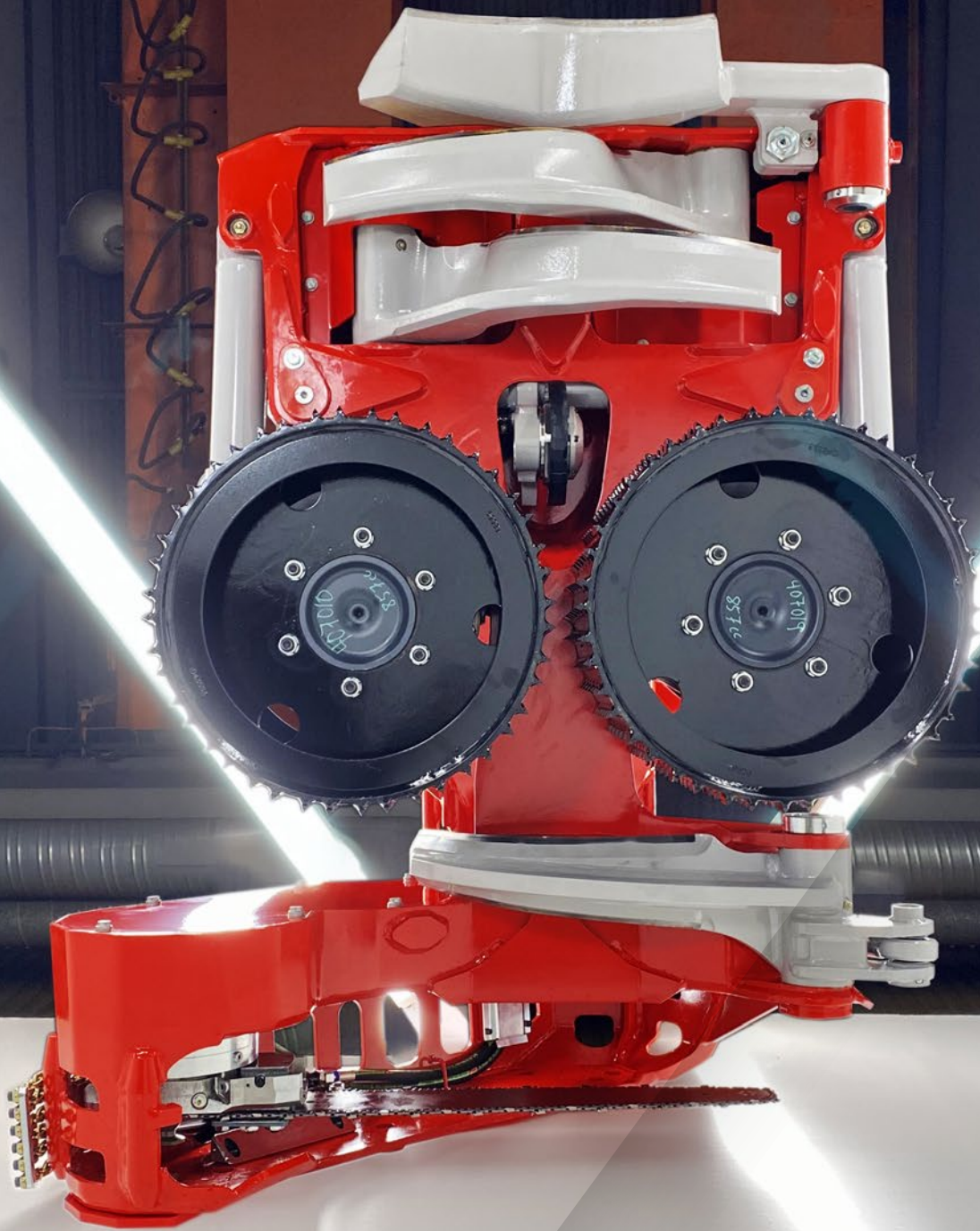

# 6000V

## The new generation all-rounder.

Improvements for 2021 model year Log Max 6000V:

- Updated attachment for the expander pin to measuring wheel arm to simplifying service and maintenance.
- Updated and reinforced saw box with bigger holes to avoid snow packing and reinforced stopper for saw unit to increase lifespan.
- Completely new main cover with new design.
- Updated wiring to saw unit inside the saw box to reduce wear and increase lifespan.
- Completely new bracket for head modules for a more stable mounting to the frame and easier assembly and disassembly.
- New XTreme-kit containing a cast felling link, reinforced protection plate and Heavy Duty protection kit. (fits only 2020 model year).

## FEATURES

# 01

### IMPROVED LENGTH MEASUREMENT FUNCTION



To offer the best measurement results, we've made some changes in the length measurement function. We have updated the construction of the measure wheel cylinder, the hydraulic circuit and reinforced the measuring wheel arm and its attachment. We also have a completely new measuring wheel unit including a bigger measuring wheel. Altogether, the changes will allow the measuring wheel to follow the contour of the stem even better and provide the best measurement result.

# 02

### AN IMPRESSIVE SAW UNIT

## 318 TrueCut



True-Cut is our smartest and fastest saw and we recommend you choose True-cut 318 that features automatic chain tensioning. The integrated valving solutions continuously senses the motor speed and adjusts the saw bar accordingly, the True-Cut maintains an almost constant chain speed of 40 m/s throughout the cutting cycle. The True-Cut is optimized at the factory and should not need any further setting changes in the field. For True-Cut to work, a minimum flow of 200l/min and a minimum pressure of 250 bar are required.



# 03

## REINFORCED FRAME AROUND MEASURING WHEEL HOLE

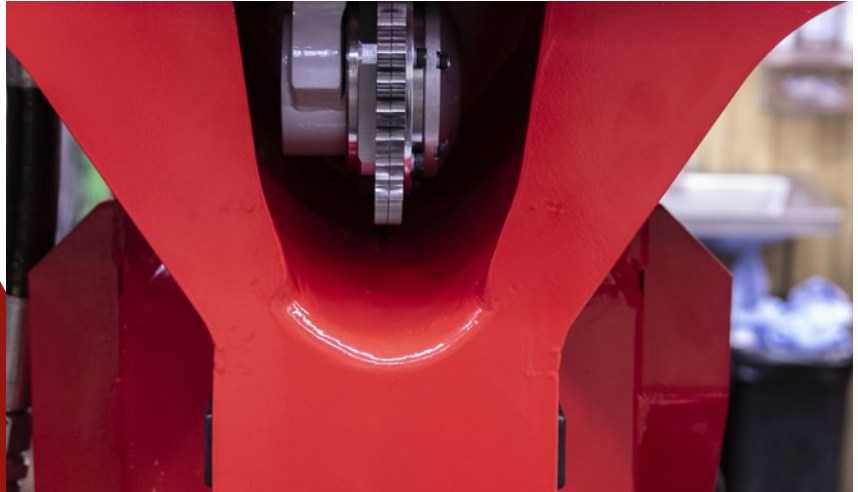

To improve the frame's durability and life span, we have changed the design of the measuring wheel hole. We also reinforced the stoppers for the roller arms, when in closed position, at the inside of the frame to increase the frame's strength and stability.

# 04

## REINFORCED FRAME AROUND UPPER KNIFE

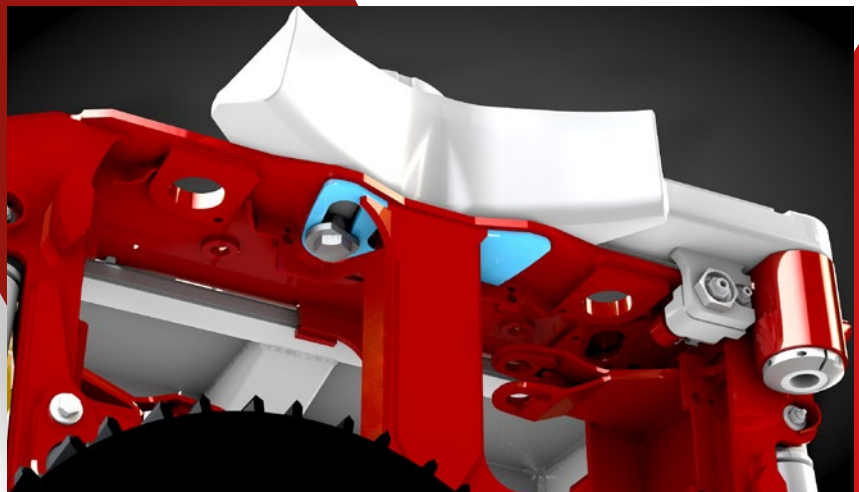

To increase durability and reduce the risk of cracks in the frame, we have created a reinforced attachment for the upper knife. The frame is reinforced at the mainline, where the upper knife slides on the frame to increase durability and extend life span.

## FEATURES

# 05

### REPLACEABLE PINS FOR FELLING LINK CYLINDER

The pins for attaching the felling link cylinder in the frame are screwed at both ends. The refinement will simplify service and maintenance.



The delimiting knife cylinder has been updated. The new cylinder has stronger attachments against the frame and knife. The update results in better durability and extended life span of the cylinder.

# 06

### NEW STRONGER HYDRAULIC CYLINDER FOR THE MAIN KNIVES

The head has a new, increased tilt angle of 5°. The change gives the unit greater mobility, which is always an advantage. It will also make it easier for the operators which works with the head in steep slopes.

# 07

### INCREASED TILT ANGLE

133°  
TILT

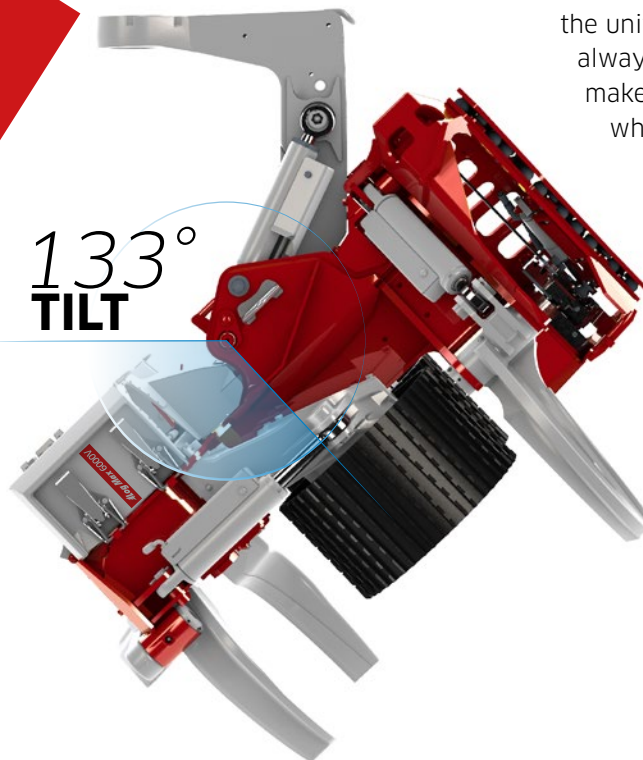

# 08

## 6000V XT-KIT

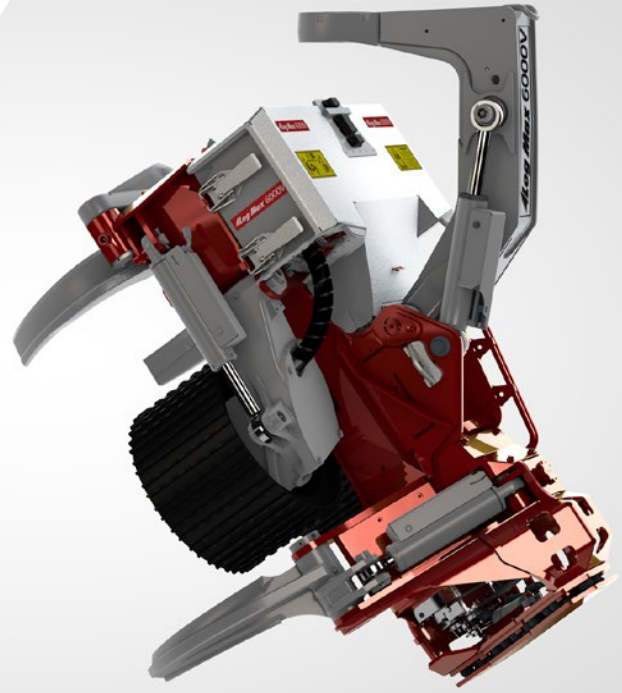

You can equip your 6000V with a XT-kit. The kit includes a reinforced casted felling link, a new reinforced fixed protection plate and Heavy Duty-protection kit. Thanks to the XT-kit your 6000V will meet the demand of the toughest operations just like the other heads in the XT-serie. The XT-kit only fits from 2020 model year 6000V.



In order to facilitate maintenance work, 6000V has easy access lubrication points. All lubrication can be done when the unit is in raised position which increases safety and shortens downtime.

# 09

## EASIER ACCESS TO GREASE NIPPLES

# 10

## LOCKABLE RING FOR ROLLER ARMS

To increase the stability of the attachment of the roller arm, we have added a lockable ring. It is located at the diameter measurement. The change will increase durability and give the unit a longer life.



# 11

## NEW HOOD DESIGN

The main cover has been updated to suit the design of the unit. We have also moved the handles for opening the cover in order to improve ergonomics.



Updated attachment for the expander pin to measuring wheel arm to simplifying service and maintenance.

# 12

## EASIER ACCESS

# 13

## UPDATED SAW BOX

Såglådan har uppdaterats med större hål i sidan för att undvika snöpackning samt ett förstärkt mekaniskt stopp i hemmaposition som ökar livslängden på sågenheten.



Completely new bracket for head module with a more stable mounting to the frame and easier assembly and disassembly.

# 14

## NEW BRACKET FOR HEAD MODULES



# EXTRA EQUIPMENT

## NEW COLOR MARKING TANK DESIGN

In order to facilitate access when refilling the color marking tanks, the tanks have been given a changed design.



## UPDATED HOSE ROUTING FOR COLOR MARKING UNIT

To reduce the risk of damage, we have updated the hose drawing to the color marking. We have moved the hoses to the inside of the frame to separate them from other hoses and thus avoid unnecessary hose wear.



## REINFORCED FELLING LINK

For you that assemble the head on an excavator or who want increased stability and expand life span, it's a good idea to supplement your head with our reinforced felling link. You also need the reinforced felling link when you equip your head with processor knives.



## NEW ATTACHMENT FOR HYDRAULIC TOP KNIFE FUNCTION

In order to simplify assembly and retrofitting, a new attachment has been created for you that wants to equip your head with a hydraulic upper knife.



## NEW PROCESSOR KNIVES

When you equip your head with processor knives, four knives are included in the kit. An upper knife that has a welded replaceable edge. A left and right delimiting knife have a modified tip for processing trees. It also includes a lower knife which has been equipped with a mechanical stop against the frame in closed position.



## 6000V XT-KIT

You can equip your 6000V with a XT-kit. The kit includes a reinforced casted felling link, a new reinforced fixed protection plate and Heavy Duty-protection kit. Thanks to the XT-kit your 6000V will meet the demand of the toughest operations just like the other heads in the XT-serie. The XT-kit only fits 2020 model year 6000V.

# 6000V IN NUMBERS

## Dimensions and weight

Weight (incl. feed rollers and cushioned protection plate, saw unit, hydraulic oil and lubrication oil)	1342 kg	2,958 lbs
Min. width	1235 mm	48.6"
Max. width	1689 mm	66.5"
Height to upper knife	1648 mm	64.8"
Height to felling link	1682 mm	66.2"
Max. full delimiting coverage	500 mm	17.3"
Max. cutting diameter	720 mm	28.3"
Min. opening between rollers, V-steel	15 mm	0.6"
Max. opening between rollers, V-steel	625 mm	24.6"
Max. opening between knives	641 mm	25.2"

## Saw units

Equipment	Saw 218/318	*Saw 218/318 True-Cut	Saw 318
Saw motor	19 ccm - 1.16 cu in	*19 ccm - 1.16 cu in	30 ccm - 1.83 cu in
Max. cutting Ø	650/710 mm - 25.6"/28"	650/710 mm - 25.6"/28"	660/720 mm - 26"/28.3"
Chain speed	max 40 m/s - 131 ft/sec	max 40 m/s - 131 ft/sec	max 40 m/s - 131 ft/sec
Saw bar standard	549518-175	549518-175	549518-475
Saw bar optional	549518-182	549518-182	549518-482
Saw chain	88/95 DL	88/95 DL / 89/96 DL	92/99 DL
Chain pitch	0.404	0.404	0.404
Chain sprocket	12Z	13Z	18Z
Chain oil swivel	Yes	Yes	Yes
Cutting control sensor	Yes	Yes	Yes
Stump treatment	optional	optional	optional
Chain oil tank	33 liters - 8.7 US gal.	33 liters - 8.7 US gal.	33 liters - 8.7 US gal.

### \*True-Cut saw unit prerequisites:

Min. flow : 200 l/min - 53 us.gal/min

Min. hydraulic pressure : 250 Bar - 3,625 psi  
At pump outlet

Min. hydraulic power: 85 kw  
Output from pump

## Felling

Felling movement	133°
Felling torque (hydraulic torque and weight torque)	7,2 kNm - 5,310 lbf-ft
Rotator	Indexator AV17S, Indexator H182
Rotator torque, max.	3,3 kNm - 2,433 lbf-ft
Max. crane size, gross lifting torque	210 kNm - 154,888 lbf-ft

## Hydraulics

Max. flow, at working revs	330 l/min - 87 us.gal/min
Min. required flow, at working revs. (to get 3,0 m/s feeding speed)	200 l/min - 53 us.gal/min
Hydraulic pressure	max 280 bar - 4,061 psi, min 250 bar - 3,625 psi
Max. hydraulic power, at working revs	ca. 154 kW
Min. hydraulic power, at working revs	ca. 84 kW
Max. recommended carrier engine power, at working revs	ca. 188 kW - 250 HP
Min. recommended carrier engine power, at working revs	ca. 103 kW - 140 HP

## Feeding

Motor type	Theoretical force	True feeding force	Speed
857cc (standard)	28,7 kN - 6,452 lbf	26,3 kN - 5,912 lbf	5,0 m/s - 16.4 ft/s
934cc (opt.)	31,3 kN - 7,036 lbf	28,5 kN - 6,407 lbf	4,6 m/s - 15 ft/s

## Weights for standard equipment

Rotator Indexator H182	64 kg - 141 lbs
Rotator Indexator HX 30	71 kg - 156 lbs
Rotator Indexator AV17S	62 kg - 136 lbs





**V** *SERIES*